



## SAMARK SAMARK 26

With up to 9 characters, variable data such as the Date, Item Number and Size can be printed.

### Durable Casing

- Ability to withstand all types of labelling conditions

### Smooth Label Dispensing

- Minimize label jams and facilitate reduction in downtime

### Wide Variety of Layouts

- Choose from a wide selection of existing layouts

### Ability To Take Special Security Cut Labels

- Tamper proof labels prevent prices from being swapped

### Precise Printout

- Clarity in printout

### Secured Label Loading

- Maximize efficiency and cost-savings

# Durable and Reliable Hand Labelling Systems

SAMARK, an excellent cost performance labeller, offers a compact, dependable & reliable hand labelling solution.

It is durably constructed to perform low to high volume labelling, allowing users to mark thousands of items quickly and reliably.

With its light-weight and specially engineered designed, SAMARK hand labellers fit the hand comfortably. Efficiency is enhanced as operators can use it daily and for longer periods of time.

SAMARK uses the most popular "punch-hole" label and SAMARK 26 uses wavy labels, which prominently set the standard for Asia and Europe respectively.

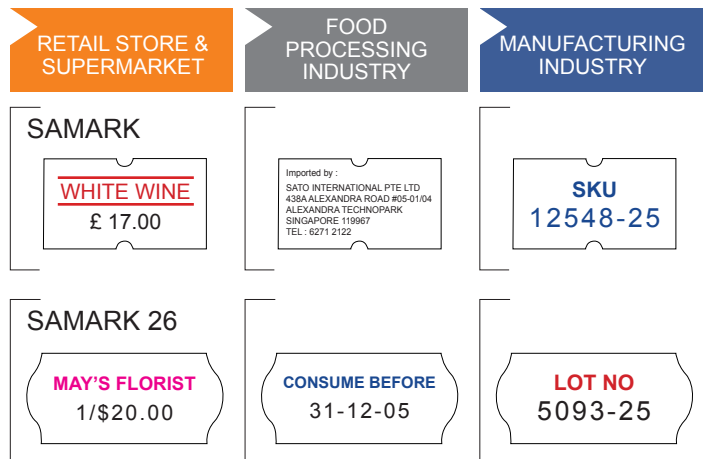

Labels shown here are for illustration purposes only

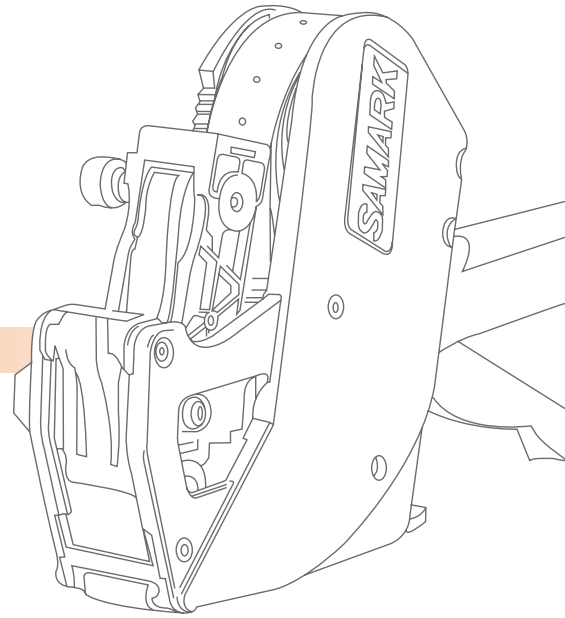

## ▶ APPLICATIONS

### Industries

- Retail stores and supermarkets
- Food processing industries
- Manufacturing industries

### Usage of Application

- Price Marking and Promotional Labelling
- Food Control. For example; Best Before date and Place of Origin
- Inventory Control. For example; SKU Code and Lot Number

## General Specifications

# SAMARK SAMARK 26

MODEL	SAMARK	SAMARK 26
Band Per Head	5, 6, 8	5, 6, 8
Font Height	3.0 to 5.0 mm (0.12" to 0.20")	3.0 to 5.0 mm (0.12" to 0.20")
Label Size	P 12 x W 21.6 mm (0.47" x 0.85")	P 12 x W 26 mm (0.47" x 1.02")
Label Type Supported	Rectangular Punch-hole	Wavy
No. Of Pieces Per Roll	1,000 pieces per roll	1,000 pieces per roll
Labeller Size	W 62 x D 226 x H 135 mm (W 2.5" x D 8.9" x H 5.3")	W 62 x D 226 x H 135 mm (W 2.5" x D 8.9" x H 5.3")
Labeller Weight	270g (without label)	270g (without label)
Body Colour	Red, Blue, Black	Red, Blue, Black

Specifications might vary from region to region and are subject to change without notice.

## Contact For more information about SATO around the globe, visit [www.satoworldwide.com](http://www.satoworldwide.com)

### AMERICAS

10350A Nations Ford Road Charlotte, NC  
28273  
Tel: (704) 644-1650  
Fax: (704) 644-1662  
E: [satosales@satoamerica.com](mailto:satosales@satoamerica.com)

### ASIA PACIFIC & OCEANIA

438B, Alexandra Road,  
#09-01/02, Alexandra Technopark  
Singapore 119968  
Tel: (65) 6271-5300  
Fax: (65) 6273-6011  
E: [sales@satoasiapacific.com](mailto:sales@satoasiapacific.com)

### EUROPE

Lambroekstraat 5A, 1831 Diegem, Belgium  
Tel: (32) 2 719 03 90  
Fax: (32) 2 719 03 99  
E: [info@be.satoeurope.com](mailto:info@be.satoeurope.com)

For sales & general enquiries: [sales@satogbs.com](mailto:sales@satogbs.com) or visit [www.satoworldwide.com/contact](http://www.satoworldwide.com/contact)